

General

Ver 1.1

S-110(G) is one of the world's smallest models, of which Persistent stability and Temperature Effect Resistance besides various outputs are much favored by customers in stocks raising, greenhouse, etc. S-110A has Automatic calibration software turned for HVAC customers who want easier monitoring with less management cost, etc.

Carbon Dioxide (CO₂)Module

Model :S-110(G)



Features

- Non-Dispersive Infrared (NDIR) technology used to measure CO₂ levels.
- Pre-calibrated
- Available output : TTL-UART, I2C
Analog Voltage (option)
- Gold-plated sensor provides long-term calibration stability.
- Installed Calibration function
- Periodic Automatic Calibration (ACDL) or Non-Periodic Manual Re-Calibration (MCDL) are available.
- Size : 33mmx33mmx13.1mm.
- Weight: 10g

S-110(G) Specifications

General Performance

Operating Temperature range : -10 ~ 60°C

Operating Humidity range : 0 ~ 95% RH (Non-condensing), 'G': 0 ~ 99% RH (Non-condensing)⁽¹⁾

Storage Temperature : -30°C ~70°C

CO₂ Measurement

Sensing Method NDIR (Non-dispersive Infrared)

Measurement Range : 0 to 2,000/3,000/5,000/10,000ppm

Accuracy : ±30ppm ±3% ⁽²⁾⁽³⁾⁽⁴⁾

Response Time(90%) : 90 seconds

Sampling Interval : 3 seconds

Electrical Data

Input Power : 5V ± 5%⁽⁵⁾

Power Consumption : Normal :14mA, Max :230mA at lamp on peak

Output connector : 4 pin, 10 pin (2mm pitch Socket)

Product Derivatives and Relative Functions

Products	Option List
S-110(G)	Calibration: H/W based MCDL & H/W based ACDL, Output: UART,I2C,AVO(option)
S-110A (ACDL S/W)	Periodic Automatic Calibration Software is added on S-110.

S-110(G) has Hardware based Periodic Automatic Calibration (ACDL, Low signal to pin-11), and Non-Periodic Manual Calibration (MCDL, Low signal to pin-13) while as S-110G was enforced to endure 99% humidity.

S-110A which has Software based Periodic Calibration in sensor, is also selectable on sale for customer whose application is Indoor Air-Quality Monitoring, operates with Periodic Automatic Calibration all the time except for times Hardware based Non-Periodic Manual Calibration (MCDL, Low signal to pin-13) is being done.

(1) S-110G: 0 ~ 99% RH (Non-condensing) for Application of Green House

(2) 2% should be added for absolute measurements for uncertainty of calibration gas mixture unless 400ppm or 0ppm standard gas calibration is done.

(3) Air pressure is assumed as 101.3 kPa..

(4) If sensor is affected by the shock, may need field calibration before installation.

(5) DC Supply should be regulated without ripple < 100mV, low noise power source is needed for best accuracy.

Pin Description for S-110(G)

[J11, J12 Pin]

J11	J11+J12	S-110(G)	S-110A (ACDL Software)
1/3	1/3	+5V VCC	
2/4	2/4	GND	
J12	J11+J12	S-110(G)	S-110A (ACDL Software)
1	5	TTL RXD (MCU→S-110)	
2	6	TTL TXD (MCU←S-110)	
3	7	I2C SCL	
4	8	I2C SDA	
5	9	GND	
6	10	Analog output (0.5~4.5V) : option	
7	11	H/W based ACDL initiation	Should be kept 'High' or disconnected
8	12	Reserved	
9	13	10 min. Manual Calibration (H/W based MCDL, Low Active)	
10	14	Reset (Low Active)	

[J13 Pin]

J-13	S-110(G)	S-110A (ACDL Software)
1	Analog Voltage Output (0.5~4.5V)	
2	Reserved	
3	GND	
4	+5V VCC	
5	TTL TXD (→ CPU of Master Board,= J12_pin2)	
6	TTL RXD (← CPU of Master Board, = J12_pin1)	
7	Reserved	
8	I2C SCL (=J12_pin3)	
9	I2C SDA (=J12_pin4)	
10	Reset (Low Active)	
11	ACDL (Low Active,= J11+J12_pin11)	Should be kept 'High' or disconnected
12	#PSEN	
13	10 min. Manual Calibration(H/W based MCDL, Low Active,= J11+J12_pin13)	

UART : 38,400BPS, 8bit, No parity, 1 stop bit TTL Level

I2C : Slave mode only, Internal pull up resister, Under 30kHz Clock

TTL Level Voltage : $0 \leq V_{IL} \leq 1.2$, $3.5 \leq V_{IH} \leq 5.0$ (Volt), $0 \leq V_{OL} \leq 0.4$, $4.2 \leq V_{OH} \leq 5$ (Volt)

Analog Voltage(Optional) : 0.5~4.5V

Dimensions (unit : mm)

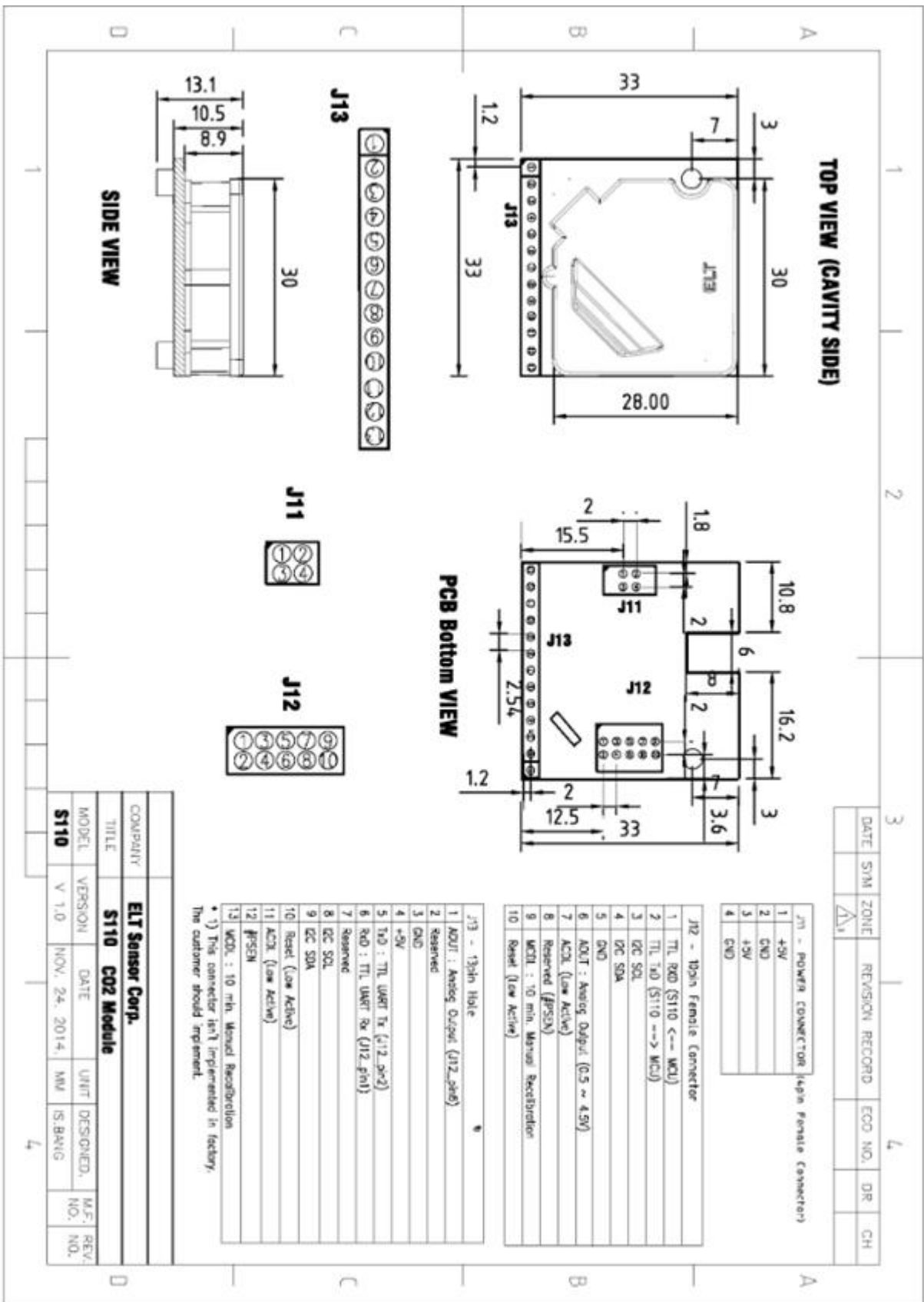

COMPANY	ELT Sensor Corp.				
TITLE	S110 CO2 Module				
MODEL	VERSION	DATE	UNIT DESIGNED	M.F. REV.	
S110	V 1.0	NOV. 24, 2014	NM	IS:BAWG NO. NO.	

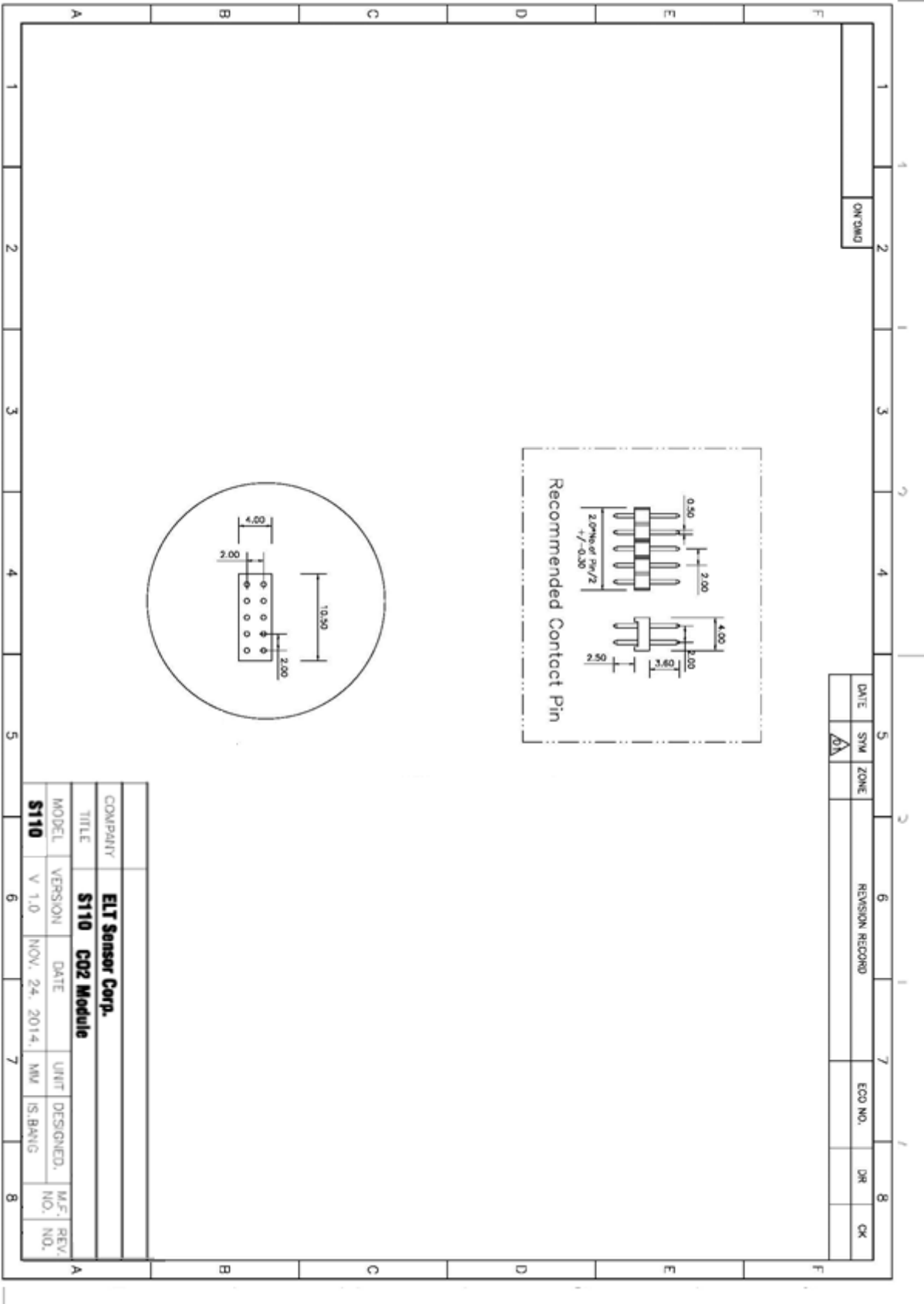

ACDL function (Automatic Calibration Function in Dimming light with period)

ACDL could be activated as by setting below.

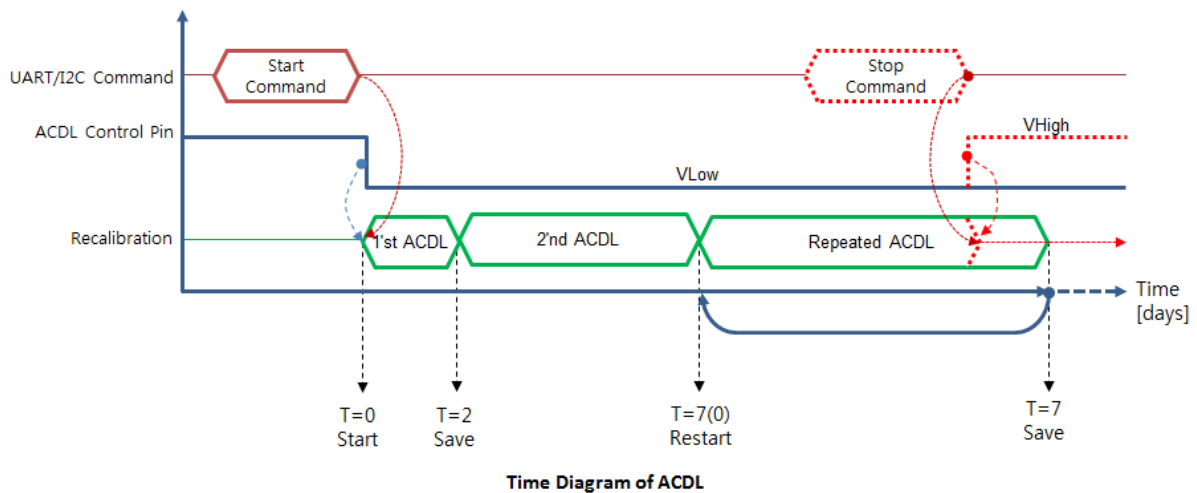

Method 1. UART Command Set; J12: pin-1 (UART-RX) and pin-2 (UART-TX) to Main-Board.
(J13: pin-6 and pin-5 are available as well)

Method 2. I2C Command Set; J12: pin-3 (SCL) and pin-4 (SDA) to Main-Board. (J13: pin-8 and pin-9 are available as well)

Method 3. Execute Hardware based ACDL.

J12:pin-7 or J13:pin-11	J12:pin-9 or J13:pin-13	Status	Notes
Low	High	H/W ACDL	Calibrate weekly after 2 days since power-on
High	High	Normal	Operate with Pre-calibrated value in Factory or previous state.

- ※ 1. (J12:pin-7 or J13:pin-11) and (J12:pin-9 or J13:pin-13) shouldn't have 'Low' at any time.
Cf.) Unlike other S-110 series, S-110A operate with software based ACDL setting, which make sensor always operate with ACDL as default unless MCDL is activated.

Method 4. **TRB-100ST (Test and Recalibration Board)** is purchasable to executable, letting sensor be located at ambient air-flow condition and execute by moving jumper following Manual, which is downloadable on the website.

Method 5. Send string command set below to RXD-pin of Sensor on Emulation program.
EK-100SL (Evaluation kit, with Emulation program 'ELTWSO') is available.

10' MCDL function (10 minute Manual Calibration Function in Dimming light).

MCDL enable customer to calibrate as needed, MCDL keep at least 10 minute once it start and should be stopped before 18minute to avoid MCDL fetch repetition.

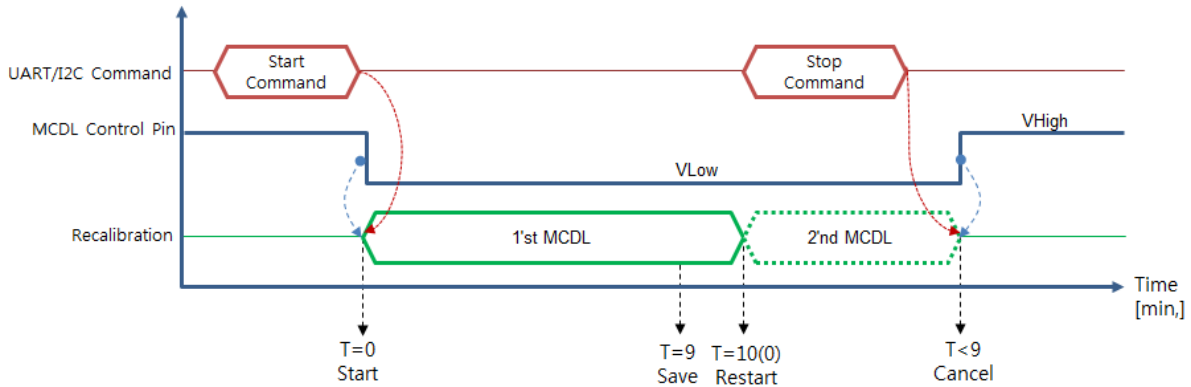

Time Diagram of MCDL

Method 1. UART Command Set; J12: pin-1 (UART-RX) and pin-2 (UART-TX) to Main-Board (J13: pin-6 and pin-5 are available as well.).

Method 2. I2C Command Set; J12: pin-3 (SCL) and pin-4 (SDA) to Main-Board. (J13: pin-8 and pin-9 are available as well.)

Method 3. Execute Hardware based MCDL.

J12:pin-7 or J13:pin-11	J12:pin-9 or J13:pin-13	Status	Notes
High	Low	H/W MCDL	Manual Recalibration – sensor should be located in 400ppm environment (outside) for 10 minutes and ‘Low’ signal to pin 13 should be done no later than 18 minutes.
High	High	Normal	Operate with Pre-calibrated value in Factory or previous state.

- ※ 1. (J12:pin-7 or J13:pin-11) and (J12:pin-9 or J13:pin-13) shouldn't have 'Low' at any time.
- 2. Be sure to quit MCDL fetch loop before 18minute.

cf.) Unlike other S-110(G) series, S-110A has nothing to do with (J12:pin-7 or J13:pin-11).

It is designed to execute MCDL during pin-13 get Low Active Signal. it return to ACDL as the signal to pin-13 is changed to High De-Active Signal.

Method 4. Let Sensor install on Jig Board, **TRB-100ST (Test and Recalibration Board)** with ambient air-flow condition and execute by moving jumper following Manual on the website.

Method 5. Send string command set below to RXD-pin of Sensor on Emulation program.

EK-100SL (Evaluation kit, with Emulation program 'ELTWSO') is available.

Comparison Table between S-110(G) and S-110A (J11+J12)

No.	S-110			S-110A (Software ACDL is default)		
	Pin-11	Pin-13	Status	Pin 11 State	Pin 13 State	Status
1	Low	High	H/W ACDL	Low	High	Reserved
2	High	High	Normal	High or disconnect	High	S/W ACDL
3	High	Low	H/W MCDL		Low	H/W MCDL
4	Low	Low	Reserved	Low	Low	Reserved

※ 'Normal' status is the same as previous state.

Output Voltage Descriptions

UART Descriptions

Data Transmit

Interval : 3 seconds

Handshake protocol : None (Data is transmitted to outer device periodically)

Data Format

D5	D4	D3	D2	D1	SP	'p'	'p'	'm'	CR	LF
----	----	----	----	----	----	-----	-----	-----	----	----

D1 ~ D5	5 byte CO2 density string
SP	Space: 0x20
'ppm'	'ppm' string
CR	Carriage return : 0x0D
LF	Line feed : 0x0A

Above 11byte consist of 5 byte hexadecimal digits, <SP>, 0x70 0x70 0x6D, <CR><LF>, where decimal '0' (corresponds to hexadecimal digit '0x30') is replaced by space (corresponds to hexadecimal digit '0x20'),

EX) 1,255 ppm, results '0x20 0x31 0x32 0x35 0x35 0x20 0x70 0x70 0x6D 0x0D 0x0A', which displays '_1255_ppm<CR><LF>' on screen.

I2C Communication (Only Slave Mode Operation)

Internal pull up resistor

Slave Address: 0x31, Slave Address Byte: Slave Address(0x31) 7 Bit + R/W 1 Bit

Bit7	Bit6	Bit5	Bit4	Bit3	Bit2	Bit1	Bit0
0	1	1	0	0	0	1	R/W Bit

R/W Bit : Read = 1/Write = 0

When reading the data, Slave Address Byte is 0x63, When writing the data, Slave Address Byte is 0x62.

Block Diagram

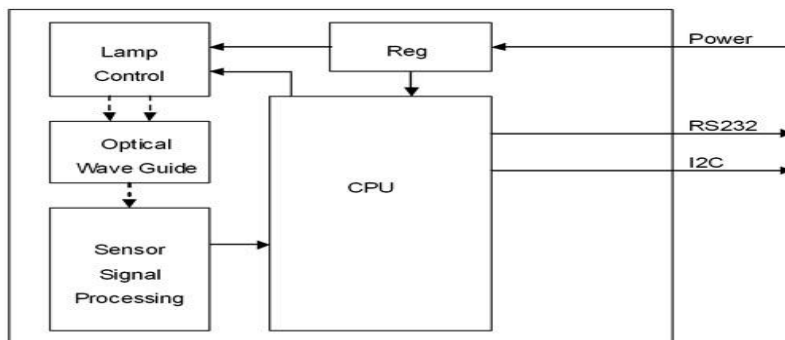

Transmission Sequence in Master

- 1) I2C Start Condition
- 2) Write Command(Slave Address + R/W Bit(0) = 0x62) Transmission and Check Acknowledge
- 3) Write Command(ASCII 'R' : 0x52) Transmission and Check Acknowledge
- 4) I2C Stop Command
- 5) I2C Start Command
- 6) Read Command(Slave Address + R/W Bit(1) = 0x63) Transmission and Check Acknowledge
- 7) Read 7 Byte Receiving Data from Module and Send Acknowledge
(Delay at least 1ms for reading each byte)

Configuration	CO ₂	reserved	reserved	reserved	reserved
1 Byte	2 Byte	0x00	0x00	0x00	0x00

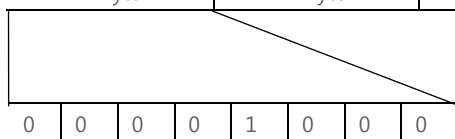

In need of detail protocol specification and time sequence, I2C programming guide is providable by contacting Sales Rep.

Analog Voltage Output Descriptions ; Option

Measured Voltage 0.5V~4.5V match proportionally to 0~ 2,000 each for 2,000 ppm scale sensor
 And any of 0~3,000 or 5,000 or 10,000 ppm scale sensor could be set by designating on sale.
 Therefore 4.5V will match 2,000 or 3,000 or 4,000 or 10,000 ppm each.

* CO2 Measurement_(ppm) = ((Output_{Voltage} - 0.5) / (4.5 - 0.5)_{Voltage}) x F.S. ppm ,
 cf. F.S. (ppm) : 2,000/3,000/5,000/10,000 ppm is optional.)

EX) if the Output_{Voltage} is 2.5V in 2,000 ppm (F.S. of Reading range)

$$\text{CO2 Measurement}_{\text{ppm}} = (2.5 - 0.5) \text{ V} \div (4.5 - 0.5) \text{ V} \times 2,000. \text{ ppm}$$

$$= 0.5 \times 2,000 \text{ ppm} = 1,000 \text{ ppm}$$

※Caution

1. Please hold only 'PCB' of sensor without holding Cavity directly to avoid the physical shock on sensor. Rough handling or Transportation could result in inaccurate reading.
 2. Proper ESD protection during handling is important to avoid electrostatic defect occurrence.
- The storage of sensor should be insulated as well

* Revision History

Version	Upgrade	Remark
1.0	Reference for revision	2015.JAN
1.1	Analog -> Option	2015.NOV